

ANNEXURE –II

Technical specification of Making switches

TABLE OF CONTENTS

Sl. No.	PARTICULARS
1.0	Foreword
2.0	General
3.0	Scope
4.0	Climatic conditions
5.0	Reference standards
6.0	System particulars
7.0	General requirements
8.0	Main Technical Data
9.0	Required design and features
10.0	Inspection and tests
11.0	Spares and Maintenance
12.0	Warranty
13.0	Installation and final acceptance
14.0	Personnel Training
15.0	Documentation

Clause No.	TECHNICAL SPECIFICATION
1.0	<p>FOREWORD:</p> <p>Central Power Research Institute (herein after referred to as CPRI) intends to establish/augment the test facilities of the High Power Laboratory in Bangalore in order to meet the growing demand for high power testing by adding two nos. of 2500 MVA Short-circuit Generators (G2 and G3). The laboratory is already having one Short circuit generator of 2500MVA capacity working since 1990. (G1).</p> <p>The total available short-circuit power (7500MVA) shall be used to increase the testing capability of the Laboratory (by running the Generators in parallel) and to improve the efficiency of testing activities making use the Generators individually to supply power to perform tests simultaneously in different test bays i.e. mainly short-circuit tests on various power system equipment such as circuit-breakers, switches, disconnecting switches, fuses, transformers, cables, etc.. In view of this, laboratory requires new Make switches (MS) intended for use for short-circuit tests (or other kind of tests) in the test bays.</p> <p>This specification covers the supply of two sets of three single-pole Make switches (MS) including all the required accessories and subsystems to properly install and operate the Make switches, ready for operation in the High Power Laboratory of CPRI-Bangalore.</p>
2.0	<p>GENERAL:</p> <p>2.1 The purpose of this specification is to give the ratings for design, manufacture, testing, installation and commissioning of the Make switches required for their use in the High Power Laboratory of CPRI-Bangalore.</p> <p>2.2 The Make switches shall be used in short circuit test laboratory for making high currents at accurate and reliable switching times and with minimum deviation so that tests can be initiated at the optimum pre-set instant.</p>

Clause No.	TECHNICAL SPECIFICATION
3.0	SCOPE:
3.1	This Scope covers the supply of two sets of three single-pole Make switches along with its all accessories and subsystems to be installed in the High Power Laboratory of CPRI-Bangalore.
3.2	This specification defines the conditions that the Make switches must satisfy the design, manufacture, characteristics, ratings and qualification testing and approval to be implemented in order to establish their compliance with the requested requirements.
3.3	<p>The supply shall include but not limited to the following;</p> <ul style="list-style-type: none"> • No. 2 sets of 3 single-pole making switches intended for use in the short-circuit generators system, at a voltage not exceeding 17.5 kV, identified as MS₂ and MS₃ in fig. (1) of the Single Line Diagram of High Power Laboratory, each pole with its own local and remote control panel; • All the required accessories, wiring, control and monitoring system and sub system needed to install and operate the making switches. If the mechanism is operated by air pressure type, the Bidder shall indicate the pressure and volumes needed. If there is a need to have a compressor, piping between air compressor and make switches and tank closed to the making switches it has to be included in the offer. • The installation and commissioning activities, by a team of specialized workers of the Bidder. • Synchronised operation with master circuit breaker and other equipment for satisfactory operation of short circuit laboratory while operating standalone and in parallel operation of Short Circuit Generators. • Special tool and tackles for maintenance purposes • Mandatory spares
3.4	<p>The Bidder shall be responsible for the following activities:</p> <ul style="list-style-type: none"> • Design • Manufacturing • Factory tests, Routine tests and Type tests • Transportation to site, unloading, handling and storage at the site • Erection & installation • Site tests • Commissioning • Personnel training of the new making switches complete with all accessories and subsystems.
3.5	These activities will be performed in a dedicated period, according to CPRI, in order to avoid interferences with other works.

Clause No.	TECHNICAL SPECIFICATION
4.0	<p>CLIMATIC CONDITIONS:</p> <p>The making switches and its accessories shall be designed for satisfactory operation under tropical climatic conditions prevailing in India.</p> <p>The climatic conditions prevalent at the site of the operation are as follows;</p> <ul style="list-style-type: none"> a) Altitude above Mean Sea Level : 921m b) Maximum ambient temperature : 45°C c) Minimum ambient temperature : 10°C d) Average annual temperature : 24°C e) Average Humidity : 81% f) Special corrosion conditions : Nil g) Solar Radiation (DNI) : 4.5-5.0 kWh/Sq. m/Day h) Atmospheric UV radiation : High i) Pollution level : Moderate j) Snow fall : NIL k) Seismic Zone : Zone-II l) Wind Speed : Average 5.6 km/h <p>The site location is situated in the CPRI campus located adjacent to Indian Institute of Science. The site can be approached</p> <ul style="list-style-type: none"> a) By Train: Nearest Railway station: Yeshwanthpur b) By Air: Kempegowda International airport 33 km away from site. c) Nearest Sea Port: Chennai
5.0	<p>REFERENCE STANDARDS:</p> <p>The making switches devoted to high power testing laboratories are special equipment. For the definition of the parameters, of the performances and for any other prescriptions given in this document, reference has to be made to the following IEC Standards</p> <p>If a relevant IEC Publication does not exist, the Bidder shall adopt other internationally accepted standards and codes.</p> <p>The making switches shall comply with the requirements of the latest edition of the following IEC Standards:</p> <ul style="list-style-type: none"> [1] IEC 62271-1: High-voltage switchgear and controlgear - Common specifications [2] IEC 62271-100: High-voltage switchgear and controlgear - Alternating current circuit breakers [3] IEC 60071-1: Insulation co-ordination – Principle definitions and rules [4] IEC 60071-2: Insulation co-ordination – Application guide

Clause No.	TECHNICAL SPECIFICATION
	<p>The relevant texts are those of the most recent editions of these standards. Reference standards are considered integral part of the present Technical Specification. The equipment has to be compliant with all Indian laws applicable.</p> <p>In the matter of conformity, the following order shall be binding:</p> <ul style="list-style-type: none"> • The requirements of this specification • The latest versions of IEC Publication • To the latest versions of other national/international standards/codes as applicable to the relevant equipment or component or the material used in the manufacture of the same. • In the event a requirement is not covered by any of the above mentioned documents the same will be decided by mutual agreement between the CPRI and the Bidder.
<p>6</p> <p>6.1</p> <p>6.2</p> <p>6.3</p>	<p>SYSTEM PARTICULARS:</p> <p>The Make switches shall be used in short circuit test laboratory for making high currents at accurate and reliable switching times and with minimum deviation so that tests can be initiated at the optimum pre-set instant.</p> <p>The Make switches shall be installed on the first floor (+9.3 meters above the ground level) of the short-circuit generator building and its location between the downstream of the Master circuit breaks and upstream of the current limiting reactors as shown in the Fig (1). The control panels and monitoring system shall be installed in the control room of short-circuit generator building accordingly the wiring system to be connected.</p> <p>The supply and wiring of the various control devices and links of the Make switches:</p> <ul style="list-style-type: none"> • Suitable system for opening and closing of the make switches (one per apparatus), located in the generator control room and in test control room and wiring of the related links as well as their connection to the terminal box associated with the control units of the make switches. • Wiring and connection of the control links transmitting the closing orders issued from the test programming units located in the test control room. • Display in the generator control room of the following make switch signals – closed position, open position, control air under pressure, control air available, suitable indications to identify the healthiness of make switches as well as wiring of the related links.

Clause No.	TECHNICAL SPECIFICATION
6.4	For running two phase and three phase tests, it is necessary to actuate each make switch along with each circuit breaker of Short Circuit Generator system separately.
7 7.1	<p>GENERAL REQUIREMENTS:</p> <p>Laboratory making switches operating conditions</p> <p>The making switches included in the scope of the present technical specifications are special switching devices normally used to make and maintain a short-circuit current during the execution of short-circuit tests (either three-phase or double-phase) or other kind of short-time high-power tests. They are not used to break any short-circuit current.</p> <p>In particular, MS(17.5)2 and MS(17.5)3 will be used to make the test current at the beginning of the test;</p> <p>A typical short circuit test sequence foresees:</p> <ol style="list-style-type: none"> 1)the application of no load nominal voltage to ground up to one terminal of the making switch; 2)the closure of the test circuit in short-circuit condition by the making switch; 3)the circulation of the test current; 4)the circuit opening by the equipment under test or by the generator master breaker; 5)the appearance of a transient recovery voltage (TRV) superimposed to the power frequency voltage with frequency up to some kHz and peak factor up to 1.9 time the peak of the power frequency voltage. <p>The nominal service of the making switches will be therefore subjected to very high thermal, dielectric and mechanical stresses; the making switches shall be designed to withstand the thermal and dynamic effects of their rated short-time current including the associated electrical stresses for the rated duration.</p> <p>The making switches shall be intended for intermittent duty only; no rated continuous current is assigned.</p> <p>7.2 Nominal duty cycles</p> <p>The making switches will be operated with the basic duty cycles described here under, at rated voltage and rated short-time current I_R as specified in clause 8.</p> <ol style="list-style-type: none"> a)No. 6 totally asymmetrical short circuits at rated current I_R, each one lasting

Clause No.	TECHNICAL SPECIFICATION
7.3	<p>0.15 s, following the operating duty cycle:</p> <p>closing operation, asymmetrical, 0.15 s ON, opening at no load; 3 min OFF;</p> <p>closing operation, asymmetrical, 0.15 s ON, opening at no load; 3 min OFF;</p> <p>closing operation, asymmetrical, 0.15 s ON, opening at no load; 3 min OFF;</p> <p>closing operation, asymmetrical, 0.15 s ON, opening at no load; 3 min OFF;</p> <p>closing operation, asymmetrical, 0.15 s ON, opening at no load; 3 min OFF;</p> <p>closing operation, asymmetrical, 0.15 s ON, opening at no load; 3 min OFF.</p> <p>At the end of this test cycle, a pause of 30 min shall be followed.</p> <p>b) No. 1 closing operation of a totally asymmetrical short-circuits at rated current I_R, repeatable every 30 minutes. The duration of the current flow shall be 1 s.</p> <p>7.3 Performances</p> <p>The requirements of relevant IEC Standards with respect to type tests, service and operation shall apply to the specified making switches, as far as they are pertinent to their ratings.</p> <p>The closing time shall not exceed the values prescribed in clause 8 and the dispersion of the closing time with respect to the nominal value shall be limited as much as possible. When the operation of the making switches is synchronized for a mechanical closing of the contacts at the instant of zero voltage, the pre-arcing time shall be as low as possible and very consistent. It has to be indicated within the technical offer.</p>
7.4	<p>7.4 Maintenance Requirements</p> <p>The making switches shall be fit for frequent mechanical operation on no-load conditions. A performance corresponding to M2 (10000 operations) class with respect to mechanical endurance is therefore required.</p> <p>In addition the making switches shall perform repeated making operations (the subsequent opening operations being on no-load) at any current up to the rated making current, before maintenance is required. Specific minimum values of the cumulative current made without maintenance shall be specified by the Bidder.</p>

Clause No.	TECHNICAL SPECIFICATION																
	<p>Emphasis is placed on the need for reliability of design in order to give long continuous service with low maintenance costs. Tender submissions shall include evidence of mechanism reliability and low contacts wear in service.</p> <p>The Bidder shall declare in his offer the making switches maintenance intervals, clarifying after how many operation:</p> <ul style="list-style-type: none"> • the making switches should be inspected visually; • mechanical operations, how many inspections and revisions (if any) are necessary within the 10000 operation (M2 class) (periodic revision) • power contacts and arcing electrodes need to be inspected for wearing; • a periodic revision of the making switches must be performed, and what this revision implies; • a major revision of the making switches must be performed, and what this revision implies. <p>The Bidder shall clarify if and when the (periodic) maintenance can be performed by CPRI's maintenance personnel (under proper training phase, to be included in the supply) and if and when the (major) maintenance must be performed by the Bidder personnel (in this case the Bidder shall clarify if the maintenance will be performed either at the CPRI's or at Manufacturer site).</p> <p>Any special tool for maintenance purposes shall be included in the present scope of supply.</p>																
8.0	<p>MAIN TECHNICAL DATA:</p> <p>The following table gives the main technical data of Make switches.</p> <p>Table 1: Main technical data of Make switches MS(17.5)2 and MS(17.5)3</p> <table border="1" data-bbox="359 1482 1388 1921"> <thead> <tr> <th>Characteristics</th> <th>Requirements</th> </tr> </thead> <tbody> <tr> <td>Number of units</td> <td>2 sets of 3 single-pole</td> </tr> <tr> <td>Installation</td> <td>Indoor</td> </tr> <tr> <td>Operating voltage</td> <td>14 kV</td> </tr> <tr> <td>Rated voltage</td> <td>17.5 kV</td> </tr> <tr> <td>Rated short-duration power-frequency withstand voltage</td> <td>38 kV</td> </tr> <tr> <td>Lightning impulse withstand voltage</td> <td>95 kV</td> </tr> <tr> <td>Rated Frequency</td> <td>50/60 Hz¹</td> </tr> </tbody> </table>	Characteristics	Requirements	Number of units	2 sets of 3 single-pole	Installation	Indoor	Operating voltage	14 kV	Rated voltage	17.5 kV	Rated short-duration power-frequency withstand voltage	38 kV	Lightning impulse withstand voltage	95 kV	Rated Frequency	50/60 Hz ¹
Characteristics	Requirements																
Number of units	2 sets of 3 single-pole																
Installation	Indoor																
Operating voltage	14 kV																
Rated voltage	17.5 kV																
Rated short-duration power-frequency withstand voltage	38 kV																
Lightning impulse withstand voltage	95 kV																
Rated Frequency	50/60 Hz ¹																

¹ The making switches shall also be able to operate at any frequency between 16 2/3 Hz and 60 Hz. The Bidder shall set down the corresponding guaranteed performances.

Clause No.	TECHNICAL SPECIFICATION	
	Rated making current Symmetrical Asymmetrical	120 kArms 360 kAp
	Rated short-time withstand current (I_R) RMS value Rated duration of current flow Peak value	120 kArms See clause 7 360 kApeak
	Fault short-time withstand current (exceptional condition) ² RMS value Rated duration of short-circuit Peak value	180 kArms 0.5 s 410 kApeak
	Rated operating time Pre-arcing time (at operating voltage) Closing time Uncertainty on closing time (pole and between poles) Opening time	< 1.1 ms < 10 ms < 0.1 ms to be defined by the Bidder
	Rated operating sequence	C - 15s - O ³
	Sequence repeatability	every 3 minutes
	Operating time in a day	10 hours
	Operating days in a year	250 days
	Design lifetime	30 years
	Number of making operations before inspection/maintenance	to be defined by the Bidder
	Centre-line distance between phases	5 to 6 meters
	Mechanical endurance class	Class M2
	Auxiliary and control circuits: rated supply voltage and rated supply frequency number and type of spare auxiliary switches	230(1- Φ)/415 (3- Φ) Vac or 220V DC (*) to be agreed with the CPRI
(*)Note: Other than 220V DC supply, the source along with the batteries shall be supplied by the Bidder meeting the operational requirements.		

² After this event, the equipment shall be inspected before restarting service.

³ Opening operation without current and voltage

Clause No.	TECHNICAL SPECIFICATION
9.0	REQUIRED DESIGN AND FEATURES:
9.1	<p>General</p> <p>MS2 and MS3 shall be designed for indoor installation with free-standing design.</p>
9.2	<p>Operating Mechanism</p> <p>The operating mechanism shall be hydraulically or pneumatically driven, complete of all requested component parts (actuators, pumps/compressors for pressure regulation, tanks etc).</p> <p>Making switches shall operate according to high reliability and declared performances over an extended lifetime, according to the requirements of clause 7.</p> <p>If the mechanism is operated by air pressure, the Bidder shall indicate the pressure and volumes needed. If there is a need to have a tank closed to the making switches it has to be included in the offer.</p>
9.3	<p>Auxiliary and control panels</p> <p>The making switches shall be supplied complete with all auxiliaries and controls necessary for proper operation in accordance with the intended use. Conceptually, the following functional subsystems can be identified:</p> <ul style="list-style-type: none"> • the local auxiliary electrical panel that provides the auxiliary power supply to the operating mechanism of the making switches and acts as an interface to the control unit for synchronised operations; it includes auxiliary switches and associated relays, control switches, control cable terminations and other auxiliary equipment; • the control unit that manages the synchronised closing operations of the making switches, receives the start order from the Laboratory Test Sequencer, monitors their status and manages the alarms. The control system shall be composed of separate units for each making switch and shall be able to operate three making switches in a synchronized way or separately. The control system shall be able to set a delay of operation from the reception of the trigger signal by the control system of the Laboratory. <p>The Bidder shall provide information on the block diagram of the making switches auxiliary and control systems, expected interfaces with the Laboratory control system and suggested installation conditions of the auxiliary and control panels.</p> <p>In particular, the Bidder shall define which kind of control signal is foreseen as closing order for a synchronised closing operation.</p>

Clause No.	TECHNICAL SPECIFICATION
<p data-bbox="245 479 292 510">9.4</p> <p data-bbox="245 891 292 922">9.5</p> <p data-bbox="245 1760 292 1792">9.6</p>	<p data-bbox="357 309 1398 421">The control system shall be immune to the interference given by the high current flowing in the power circuit and in the surrounding equipment. The Bidder shall declare in his offer the immunity level of the control system.</p> <p data-bbox="357 479 584 510">Operation mode</p> <p data-bbox="357 533 1238 564">The operating mechanism shall allow the following operation mode:</p> <ul data-bbox="405 586 1398 739" style="list-style-type: none"> <li data-bbox="405 586 1398 654">• Local operation. Local electrical operation by push-buttons placed on local auxiliary electrical panel. <li data-bbox="405 667 1398 739">• Remote operation. Electrical operation from control unit and test sequencer from test control room. <p data-bbox="357 761 1398 828">The selection of any one of the above position shall exclude the possibility of operation from the other position.</p> <p data-bbox="357 891 612 922">Auxiliary contacts</p> <p data-bbox="357 945 1398 1057">Sufficient nos. of N/O and N/C auxiliary electrical contacts shall be provided for using in interlocking circuits and for status indications at the remote and supervisory control centres and any other requirement.</p> <p data-bbox="357 1093 1398 1205">Each generator make switch pole shall be equipped with at least the following auxiliary contacts of high reliability so as to ensure the exact status of the make switches:</p> <ul data-bbox="405 1236 874 1397" style="list-style-type: none"> <li data-bbox="405 1236 874 1267">• 4 contacts NC in open position <li data-bbox="405 1281 874 1312">• 4 contacts NC in closed position <li data-bbox="405 1326 874 1357">• 4 contacts NO in open position <li data-bbox="405 1370 874 1402">• 4 contacts NO in closed position <p data-bbox="357 1482 1398 1684">The signal for “Making Switch closed” shall be given only after complete closing, which means that a rated current can run through the making switches, while the signal for “Making Switch open” shall be given only after the complete opening when the isolating distance is sufficient to withstand with success the required dielectric test.</p> <p data-bbox="357 1760 1193 1792">Type of materials used for no current parts of making switch</p> <p data-bbox="357 1814 1398 1971">The no current carrying metallic parts of the making switches can be either made of hot dip galvanized steel or stainless steel. Cast iron can be used only in places where applied forces are not relevant. Cast iron shall also be hot dip galvanized.</p>

Clause No.	TECHNICAL SPECIFICATION							
<p>9.7</p> <p>9.8</p> <p>9.9</p>	<p>Type of materials used for assembly components of making switch All bolts, nuts and washers which are used in current carrying parts of the making switches shall either be of stainless steel or bronze. All bolts, nuts and washer which are used in the no current parts of the making switch shall be hot dip galvanized steel or stainless steel.</p> <p>Operating mechanism housing The housing of the operating mechanism shall be of hot-dip galvanized steel. For the making switches intended for indoor installation the minimum degree of protection of the housing shall be IP21, see IEC 60529. For outdoor installation, the minimum degree of protection of the housing shall be IP55.</p> <p>The housing of the operating mechanism, as well as the local control panel, shall be equipped with anti-condensation heater controlled by thermostat (230V, 50Hz supplied) if necessary.</p> <p>Marking and plates Marking and plates shall comply with relevant IEC standards and with all relevant Indian standards.</p>							
<p>10.0</p> <p>10.1</p> <p>10.2</p>	<p>INSPECTIONS AND TESTS:</p> <p>Inspection during manufacturing The Bidder shall propose a comprehensive inspection program during manufacture of the making switches.</p> <p>CPRI representatives shall be allowed to inspect the production process in the factory.</p> <p>Type tests Making switches shall have been type tested according to a specific test program to be communicated to the CPRI, based on the technical feasibility and following IEC Standards [1] and [2] where applicable.</p> <p>In principle the following type of tests shall have been performed, for which reference to the corresponding clause of IEC 62271-100 is given hereinafter, as far as applicable.</p> <table border="1" data-bbox="344 1883 1402 2024"> <thead> <tr> <th data-bbox="344 1883 437 1980">No.</th> <th data-bbox="437 1883 1070 1980">TESTS</th> <th data-bbox="1070 1883 1402 1980">IEC 62271-100 Clause</th> </tr> </thead> <tbody> <tr> <td data-bbox="344 1980 437 2024">1</td> <td data-bbox="437 1980 1070 2024">General</td> <td data-bbox="1070 1980 1402 2024">6.1</td> </tr> </tbody> </table>		No.	TESTS	IEC 62271-100 Clause	1	General	6.1
No.	TESTS	IEC 62271-100 Clause						
1	General	6.1						

Clause No.	TECHNICAL SPECIFICATION																										
	2	Dielectric tests	6.2																								
	3	Measurement of the resistance of circuit	6.4																								
	4	Temperature-rise tests	6.5																								
	5	Short-time withstand current and peak withstand current tests	6.6																								
	6	Mechanical and environmental tests	6.101																								
	7	Basic short-circuit test-duty TD 100 S, restricted to making operations	6.106.4.4																								
	Type test repetition it's not required provided that the Bidder can submit valid type test certificates. Otherwise type test will be performed at Bidder exclusive cost.																										
10.3	<p>Routine tests</p> <p>Making switches shall be subjected to routine tests according to a specific program to be agreed with the CPRI, based on the technical feasibility and following IEC Standards [1] and [2] where applicable, to verify the quality and performances of the product.</p> <p>In principle the following type of tests shall be performed, for which reference to the corresponding clause of IEC 62271-100 is given hereinafter, as far as applicable.</p> <table border="1" style="width: 100%; border-collapse: collapse;"> <thead> <tr> <th style="text-align: center;">No</th> <th style="text-align: center;">TESTS</th> <th style="text-align: center;">IEC 62271-100 Clause</th> </tr> </thead> <tbody> <tr> <td style="text-align: center;">1</td> <td>Dielectric test on the main circuit</td> <td style="text-align: center;">7.1</td> </tr> <tr> <td style="text-align: center;">2</td> <td>Dielectric test on the auxiliary and control circuits</td> <td style="text-align: center;">7.2</td> </tr> <tr> <td style="text-align: center;">3</td> <td>Measurement of the resistance of the main circuit</td> <td style="text-align: center;">7.3</td> </tr> <tr> <td style="text-align: center;">4</td> <td>Tightness Test</td> <td style="text-align: center;">7.4</td> </tr> <tr> <td style="text-align: center;">5</td> <td>Mechanical operation tests (including resistance and current measurements of closing coils and checking anti-pumping function)</td> <td style="text-align: center;">7.101</td> </tr> <tr> <td style="text-align: center;">6</td> <td>Design and visual checks</td> <td style="text-align: center;">7.5</td> </tr> <tr> <td style="text-align: center;">7</td> <td>Timing test of making switch (including measurement of operating time, stroke, speed, current consumption of closing coil and also auxiliary contacts of close coil). The uncertainty of closing times shall be evaluated.</td> <td style="text-align: center;">--</td> </tr> </tbody> </table>			No	TESTS	IEC 62271-100 Clause	1	Dielectric test on the main circuit	7.1	2	Dielectric test on the auxiliary and control circuits	7.2	3	Measurement of the resistance of the main circuit	7.3	4	Tightness Test	7.4	5	Mechanical operation tests (including resistance and current measurements of closing coils and checking anti-pumping function)	7.101	6	Design and visual checks	7.5	7	Timing test of making switch (including measurement of operating time, stroke, speed, current consumption of closing coil and also auxiliary contacts of close coil). The uncertainty of closing times shall be evaluated.	--
No	TESTS	IEC 62271-100 Clause																									
1	Dielectric test on the main circuit	7.1																									
2	Dielectric test on the auxiliary and control circuits	7.2																									
3	Measurement of the resistance of the main circuit	7.3																									
4	Tightness Test	7.4																									
5	Mechanical operation tests (including resistance and current measurements of closing coils and checking anti-pumping function)	7.101																									
6	Design and visual checks	7.5																									
7	Timing test of making switch (including measurement of operating time, stroke, speed, current consumption of closing coil and also auxiliary contacts of close coil). The uncertainty of closing times shall be evaluated.	--																									
	The Bidder shall inform CPRI of the Acceptance Tests program 60 days in advance and shall allow CPRI representatives to witness them.																										

Clause No.	TECHNICAL SPECIFICATION
10.4	<p>Special tests (short-circuit cycle tests)</p> <p>The execution of the special tests is subjected to CPRI decision. Alternatively the Bidder may demonstrate the capability of his product by appropriate certifications.</p> <p>Short circuit cycle test foresees the application of the rated duty cycles to be withstood by the making switches (defined in clause 7.2).</p> <p>The following test cycle shall be the withstood with success:</p> <ol style="list-style-type: none"> 1. Application of duty cycle a) of clause of 7.2 2. After 30 minutes, application of duty cycle b) of clause 7.2 <p>Test procedure and evaluation of results shall comply with relevant IEC Standards.</p> <p>All the above tests (type, routine and special tests), measurements and verifications are totally included under the Bidder scope of work and shall be performed on all the furnished equipment in accordance to relevant standards.</p>
11.0	<p>SPARES AND MAINTENANCE:</p> <p>The bidder shall have to propose and quote for mandatory spares, which are mandatory to be procured for first ten years normal operation. Mandatory spares quote shall be included in the main equipment cost for bid evaluation purpose.</p> <p>The bidder shall have to propose and quote for recommended spares with a minimum validity of one year. Recommended spares quote shall not be included in the main equipment cost for bid evaluation purpose.</p> <p>The Bidder shall quote as OPTION:</p> <ul style="list-style-type: none"> • one complete spare pole for each making switch type; • spare unit/parts for the making switches control system. <p>The bidder shall supply all the special tools and tackles necessary for both routine & main maintenance and mounting or dismounting operations as regards removable equipment.</p> <p>The bidder shall indicate the maintenance schedule proposed during the guarantee period and service life of the various items of equipment offered, when operated and maintained in accordance with instructions of the manufacturers.</p>
12.0	<p>WARRANTY:</p> <p>The Bidder will guarantee, for the duration indicated in the tender documents from the date of the commissioning, all the making switches and accessories,</p>

Clause No.	TECHNICAL SPECIFICATION
	<p>with reference to materials quality and declared performances.</p> <p>In case of damages resulting from the Bidder supply and activities, the Bidder will substitute at its expenses the faulty parts and all the parts not compliant with declared performances.</p>
13.0	<p>INSTALLATION AND FINAL ACCEPTANCE:</p> <p>The making switches shall be installed in CPRI HPL in Bangalore and tested for final acceptance.</p> <p>The presence of the Bidder on-site is requested to give assistance during the installation (to be done at CPRI charge) and to check the correct operation of the making switches.</p> <p>The CPRI will then perform mechanical and electrical tests on the installed making switches, aimed to the final acceptance of the supply.</p> <p>The specific test program is to be agreed between Bidder and CPRI based on the technical feasibility and following IEC 62271-1 and IEC 62271-100 where applicable, with the aim of verifying the fulfilment of the making switches to the parameters of tables at clause 8, as declared by the Bidder, and to verify the control system operation and performance under the real operating conditions.</p> <p>The Bidder shall witness the tests and countersign the acceptance test report.</p> <p>No damage shall result from the tests.</p> <p>They will be commissioned after satisfying all above tests and providing their compliance with all the requirements of this specification.</p> <p>Equipment could be energized only after the personnel performing the tests have certified that said equipment is ready for energizing and after approval by CPRI.</p> <p>The bidder shall then provide all the necessary documents, updated, to allow the operation and maintenance teams to work on the equipment after completion of the personnel training programme.</p> <p>CPRI shall be entitled to reject any of the equipment if it does not fulfil duty requirements and tests as specified in this document.</p>
14.0	<p>PERSONNEL TRAINING:</p> <p>During erection and acceptance tests at site, the bidder shall have to organize a training programme for CPRI's maintenance and operation teams. Bidder shall plan the erection period in compliance with the general schedule.</p>

Clause No.	TECHNICAL SPECIFICATION
	<p>The personnel constituting his own starting up team shall be sufficient and shall have the right qualification level to implement this training programme which will last for 3 days during erection and commissioning.</p> <p>The content of the suggested programme shall be submitted in the bid.</p>
15.0	<p>DOCUMENTATION:</p> <p>The information to be submitted with the offer shall include:</p> <ul style="list-style-type: none"> • Technical pamphlets and brochures of the offered making switches which will help the technical evaluation process. • Outline drawing showing overall dimensions of the making switches, drawing indicating terminal markings as well as any information, sketches and data necessary for a complete description of the proposal. • Mechanical and electrical endurance data. • Any type test certificates for the type and special test specified in the present specifications. • List of spare parts. • Maintenance program. • Any special tool for maintenance purposes. <p>The following documents shall be provided along with the supply:</p> <ul style="list-style-type: none"> • General drawings, electrical schemes, installation drawings. • Operation manual and Maintenance manual: the manuals shall contain specific diagrams with complete instructions relevant to storage, handling, construction, commissioning, troubleshooting, servicing. • The curve of making switches capabilities in terms of made currents / cumulated current (electrical endurance) before any maintenance is requested. • Reports of in-production inspections. • Reports of routine/acceptance tests performed on making switches. <p>All documents shall be issued in English and provided both on paper and digital format.</p>

Fig (1) : High Power Laboratory

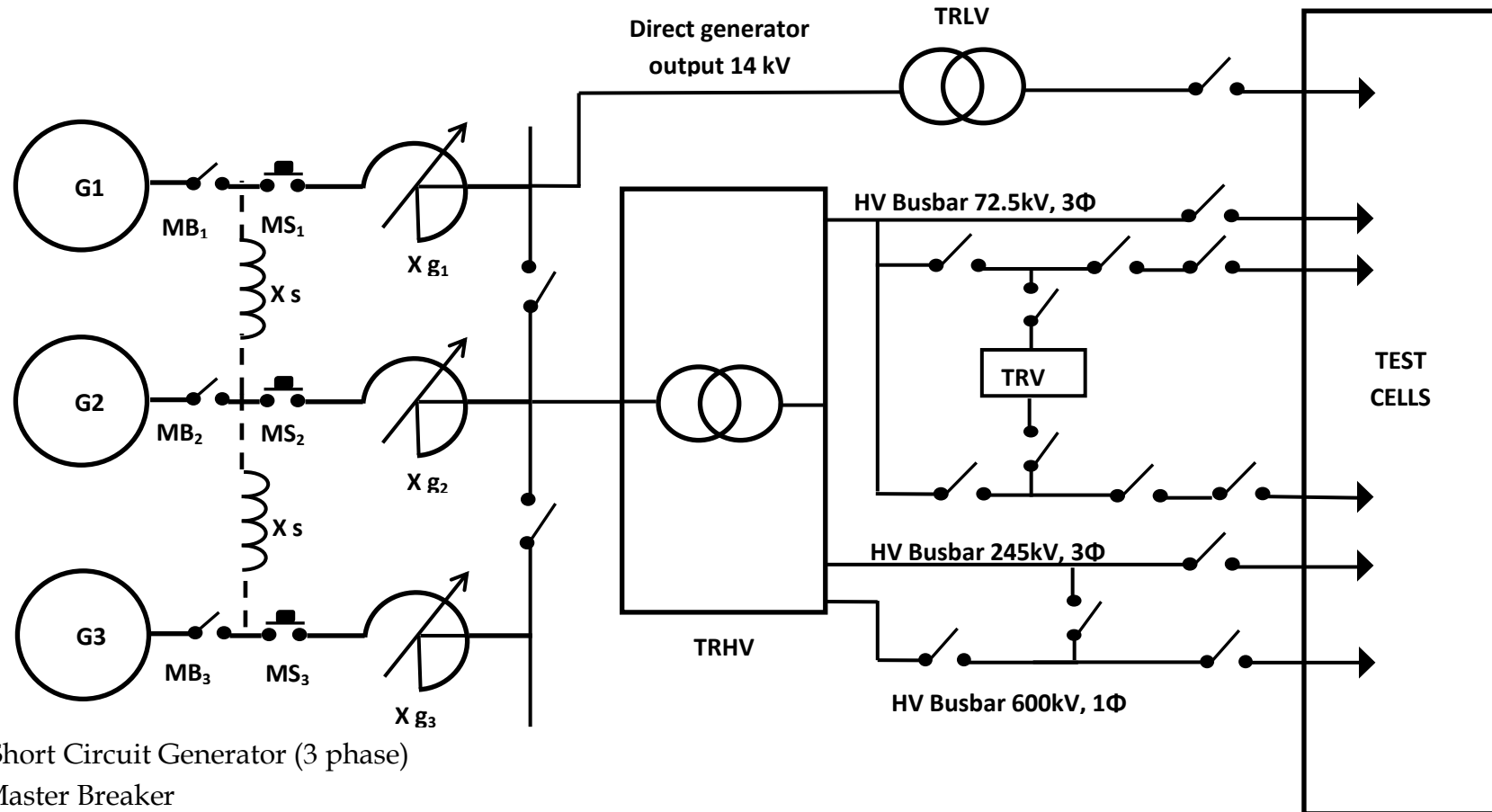

LEGEND

G : Short Circuit Generator (3 phase)

MB : Master Breaker

MS : Make Switch

X : Adjustable reactors

X_s : Synchronizing reactors

TRHV: Step up transformer

TRLV : 300kA high current transformer

TRV :TRV adjustment elements